

SCM2 系列离心泵

SERIES CENTRIFUGAL PUMPS



SCM2 series are with two impellers back to back, because of two impeller to gain energy, it is an obvious choice that there is need for high head values but if hard to reach with single impeller centrifugal pumps. Suitable for civil and industrial uses to pump clean water and chemically non-aggressive liquid. Particularly be used for increasing the supply pressure, feeding boilers and loading extremely.

SCM2系列电泵有两个背靠背的叶轮，可以产生较高的扬程。应用于民用及工业场合输送清水及不具腐蚀性的流体，特别适用于系统增压，低压锅炉给水等需要高扬程的场合。

WORKING CONDITIONS

- Max Temperature of Fluid up to +60°C
- Max Pressure 10bar
- Max Ambient Temperature up to 40°C

工作条件：

- 最高流体温度为60°C
- 最大可承受的压力10bar
- 最高环境温度40°C

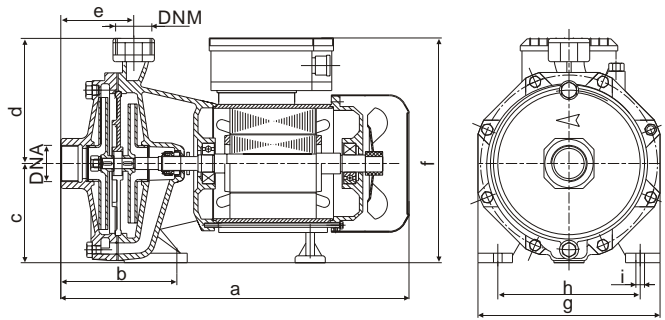
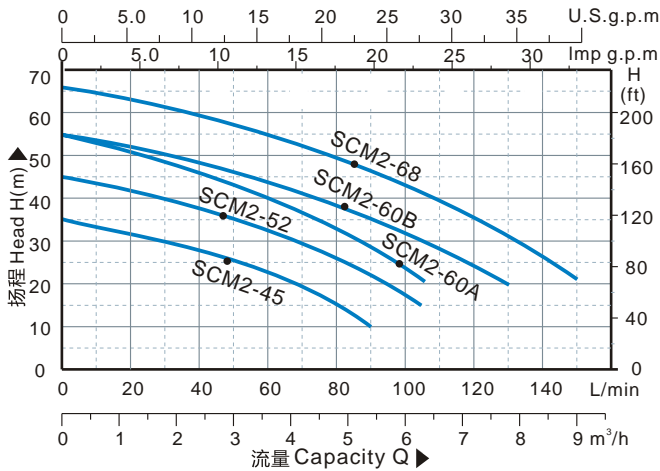

技术参数 TECHNICAL DATA AT 220~240V/50Hz

型号 TYPE	输入功率 Input Power		电流 Current (A)	最大流量 Q _{max} (l/min)	最高扬程 H _{max} (m)	最大吸程 S.Head (M)	转速 Speed (r/min)	流量 Capacity(l/min)										
	KW	HP						Total head(m)										
SCM2-45	0.75	11	4.6	90	35	9	2850	0	20	40	60	80	100	110	120	130	140	
SCM2-52	1.1	1.5	6.8	105	45	9		35	31	27	22	15						
SCM2-60A	1.5	2	8.6	105	55	9		45	41	37	32	25	17					
SCM2-60B	1.5	2	8.6	130	55	9		55	50	45	40	32	23	20	10			
SCM2-68	2.2	3	12.8	150	66	9		55	52	49	44	37	31	28	25	20		
								66	62	59	55	50	42	39	35	30	25	

Note: 110V/60Hz, 115V/60Hz, 127V/60Hz, 110/220V/60Hz, 380V/50Hzets. Models are available on request
备注: 可以按要求生产110V/60Hz, 115V/60Hz, 127V/60Hz, 110/220V/60Hz等电压频率

安装尺寸 DIMENSIONS

型号 TYPE	外形尺寸 Dimensions(mm)												包装尺寸 Packing Size (mm)			毛重 G.W KG	包装数量 Packing QT 20柜(Cont)	
	进口 DNA		出口 DNM		a	b	c	d	e	f	g	h	i	L	W			H
	inch	mm	inch	mm														
SCM2-45	1.25"	30	1"	25	379	135	110	153	84	263	225	185	11	210	380	240	18	1100
SCM2-52	1.25"	30	1"	25	400	140	115	148	86	256	210	165	10	420	230	280	23.5	850
SCM2-60A	1.25"	30	1"	25	400	140	115	148	86	256	210	165	10	420	230	280	25	800
SCM2-60B	1.5"	40	1.5"	40	400	140	115	148	86	256	210	165	10	420	230	280	25	800
SCM2-68	1.5"	40	1.25"	30	450	160	140	175	90	320	240	200	14	480	290	350	31	650